

SINGLE-LEVER PILLAR MIXER

F5LM1002 | 2030029885

PRODUCT GROUP : Taps | ARTICLE FAMILY : Manual taps | ARTICLE GROUP : F5LM1002 ++ | LIFECYCLE : New |
MODEL RANGE : F5

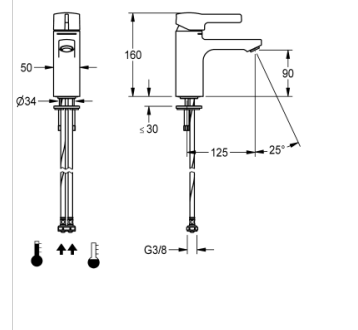

F5L-Mix single-lever mixer as pillar mixer DN 15 for sanitary facilities. Mixing cartridge with ceramic disc technology and thermostatic protection from scalding, permanently set to 41 °C and with safety switch-off in the event of failure of the cold water supply. With a mechanism for an optional hygiene unit for automatic hygiene flushing and program-controlled thermal disinfection. For connection to hot water and cold water via hoses, includes strainers. All-metal construction, high-polished chromium-plated brass. Anti-theft aerator, SLIM design, with integrated flow rate regulator 5.0 l/min, projection 125 mm.

TECHNICAL DATA

Gross weight	1.74 kg
Net weight	1.70 kg
Functional principle	manual
Type of mixing	with thermostat / mixer
Type of mounting	TAPHOLE
Type of tap	pillar tap
calculation flow rate cold water	0.07 liter per second
calculation flow rate hot water	0.07 liter per second
depressurised	no
Diameter nominal	DN 15
Material fitting	brass
minimum flow pressure	1.00 bar
spout projection	125.00 mm
Surface finish fitting	chromed
thermal disinfection	prepared for automatic thermal disinfection
Type of operation	manual operation
volume flow rate at 3 bar	0.08 liter per second
Inlet size	G3-8
Sound insulation	no
hygiene flushing	prepared
Product code	208.0511.858

